

40Gb/s Active optical cable with breakout from 40G QSFP+ to 4x 10G SFP+

Luxglo AOC is a 4x10 Gb/s parallel active optical cable for storage, data, and high-performance computing interconnectivity. It transmits four separate streams of 10 Gb/s data over ribbon cables in a point-to-multipoint configuration. The cable contains a QSFP+ module on one end and four separate SFP+ modules at the other ends. Designed with MSA-compliant QSFP+ and SFP+ high-density connectors, these cables are compact, lightweight, and low power. With reaches up to 50 meters, the active optical cable is ideally suited for high-density 10G Ethernet, InfiniBand QDR, and other datacom and high-performance computing applications.

Features

- Four-channel full-duplex active optical
- cable with breakout from QSFP+ to four SFP+
- 1G to 10.5 Gbps data rate per channel
- Support hot-pluggable
- Available in lengths of 1 to 50m
- 360 degree active optical cable braid crimp
- and enhanced EMI skirt Excellent ESD protection Single 3.3V power supply
- RoHS Compliant and Lead-Free Complies with QSFP+ and SFP+ MSA form factors
- Commercial operating case temperature
- range: 0°C to 70°C

Applications

- 40G Ethernet
- InfiniBand 4X SDR DDR
- QDR Other 40G connection



Regulatory Compliance

- ESD to the Electrical PINs: compatible with MIL-STD-883E Method 3015.7 Immunity
- compatible with IEC 61000-4-3
- EMI compatible with FCC Part 15 Class B EN55022 Class B ROHS
- compliant with ROHS 2 (2011/65/EU)

Pin Descriptions

a. QSFP+ End

Pin	Symbol	Name	Ref.
1	GND	Ground	1
2	Tx2n	Transmitter Inverted Data Input	
3	Tx2p	Transmitter Non-Inverted Data output	
4	GND	Ground	1
5	Tx4n	Transmitter Inverted Data Input	
6	Tx4p	Transmitter Non-Inverted Data output	
7	GND	Ground	1
8	ModSelL	Module Select	
9	ResetL	Module Reset	
10	VccRx	+ 3.3V Power Supply Receiver	2
11	SCL	2-Wire Serial Interface Clock	
12	SDA	2-Wire Serial Interface Data	
13	GND	Ground	
14	Rx3p	Receiver Non-Inverted Data Output	
15	Rx3n	Receiver Inverted Data Output	
16	GND	Ground	1
17	Rx1p	Receiver Non-Inverted Data Output	
18	Rx1n	Receiver Inverted Data Output	
19	GND	Ground	1

20	GND	Ground	1
21	Rx2n	Receiver Inverted Data Output	
22	Rx2p	Receiver Non-Inverted Data Output	
23	GND	Ground	1
24	Rx4n	Receiver Inverted Data Output	1
25	Rx4p	Receiver Non-Inverted Data Output	
26	GND	Ground	1
27	ModPrsL	Module Present	
28	IntL	Interrupt	
29	VccTx	+3.3 V Power Supply transmitter	2
30	Vcc1	+3.3 V Power Supply	2
31	LPMoDe	Low Power Mode	
32	GND	Ground	1
33	Tx3p	Transmitter Non-Inverted Data Input	
34	Tx3n	Transmitter Inverted Data Output	
35	GND	Ground	1
36	Tx1p	Transmitter Non-Inverted Data Input	
37	Tx1n	Transmitter Inverted Data Output	
38	GND	Ground	1

Notes:

1.GND is the symbol for signal and supply (power), Connect these directly to the host board signal common ground plane 2.VccRx, Vcc1 and VccTx are the receiving and transmission power suppliers and shall be applied concurrently. Vcc Rx,

Vcc1 and Vcc Tx may be internally connected within the QSFP+, The connector pins are each rated for a maximum current of 500mA.

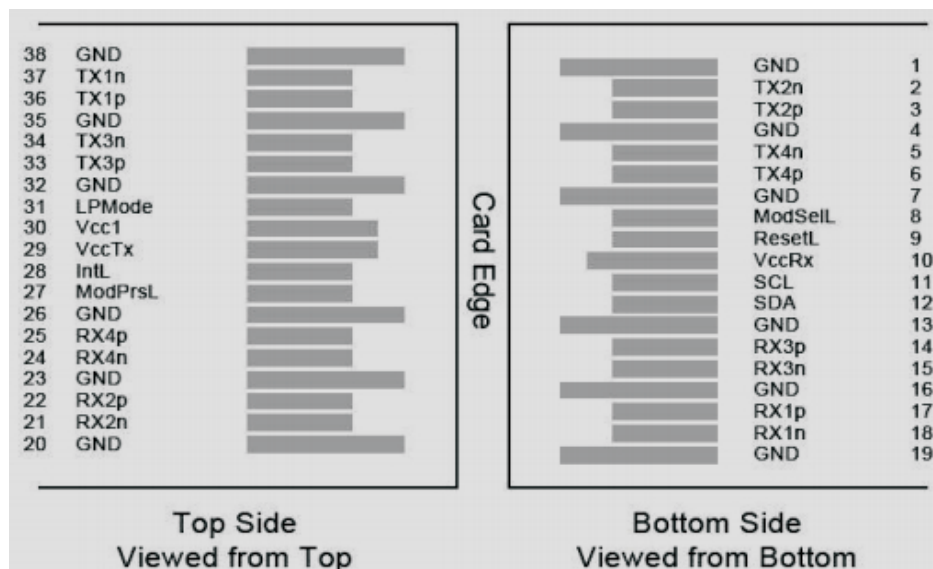

Pin Descriptions

b. SFP+ End

Pin	Symbol	Name	Ref.
1	VeeT	Transmitter Ground ,Common with Receiver Ground in Module	
2	TX Fault	Transmitter Fault	
3	TX Disable	pulled to VccT with 4.7k to 10k ohm in Module	
4	SDA	2-Wire Serial Interface Data Line(Same as MOD-DEF2 in INF-8074i).	
5	SCL	2-Wire Serial Interface Clock Line(Same as MOD-DEF2 in INF-8074i).	
6	Mod_ABS	Module Absent, Connect to VeeT or VeeR in Module.	
7	RS0	N/A	
8	LOS	pulled to VeeR in Module	
9	RS1	N/A	
10	VeeR	Receiver Ground	
11	VeeR	Receiver Ground	
12	RD-	Receiver Inverted DATA out, AC Coupled,	
13	RD+	Receiver Non-inverted DATA out, AC Coupled,	
14	VeeR	Receiver Ground	
15	VccR	Receiver Power Supply	
16	VccT	Transmitter Power Supply	
17	VeeT	Transmitter Ground	
18	TD+	Transmitter Non-Inverted DATA in. DC Coupled,	
19	TD-	Transmitter Inverted DATA in. DC Coupled,	
20	VeeT	Transmitter Ground	

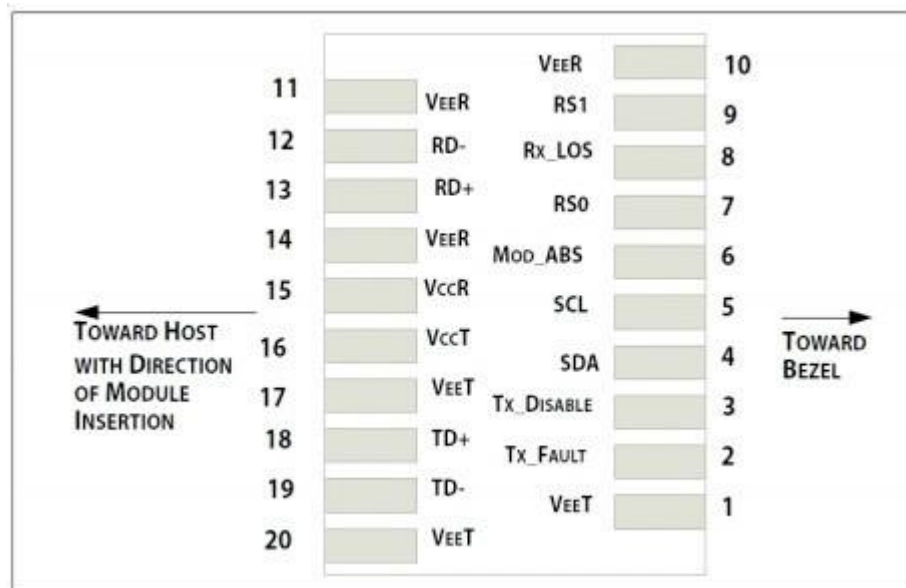

SFP+ Electrical Pad Layout

Absolute Maximum Ratings

Parameter	Symbol	Min	Typ	Max	Unit	Ref.
Maximum Supply Voltage	Vcc	-0.5		4	V	
Storage Temperature	TS	-4		85	°C	
Operating Humidity	RH	0		85	%	
Parameter		Min	Typ	Max	Unit	
Minimum bend radius			60		mm	
Minimum bend radius within 100 mm of a module end		105			mm	
Diameter of common (non-broken-out) cable jacket		3	3.3	3.6	mm	
Diameter of broken-out cable jacket		1.8	2	2.2	mm	

Recommended Operating Conditions

Note: 430mA for QSFP+ end, 100mA for SFP+ end.

Parameter	Symbol	Min	Typ	Max	Unit	Ref
Power Supply Voltage	Vcc	3.13	3.3	3.47	V	
Power Supply Current	Icc	-	-	430/100	A	Commercial
Case Operating Temperature	Tc	0	-	70	°C	Commercial
Bit Rate Each Lane	Br		10.3	11.3	Gbps	

Electrical Characteristics (TOP=25°C, Vcc=3.3Volts)

Parameter	Symbol	Min	Typ	Max	Unit	Ref
Data Rate, each Lane			10.3	11.3	Gbps	
Control I/O Voltage, High	VIH	2		Vcc+0.3	V	
Control I/O Voltage, Low	VIL	Vee		Vee+0.8	V	
QSFP+/SFP+ End Transmitter						
Tx Input Diff Voltage	Vi	100		1000	mV	
Tx Input Diff Impedance	Zi	80	100	120	Ω	
QSFP+/SFP+ End Receiver						
Rx Output Diff Voltage	Vo		600	800	mV	
Rx Output Diff Impedance	Zo	80	100	120	Ω	

Mechanical Specifications

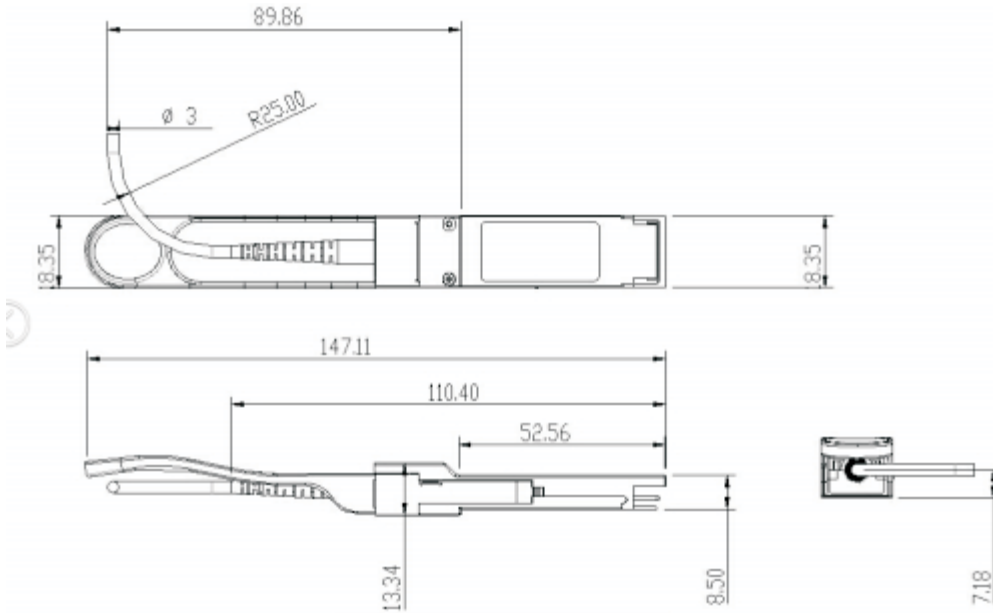

QSFP+ AOC end Mechanical Specifications

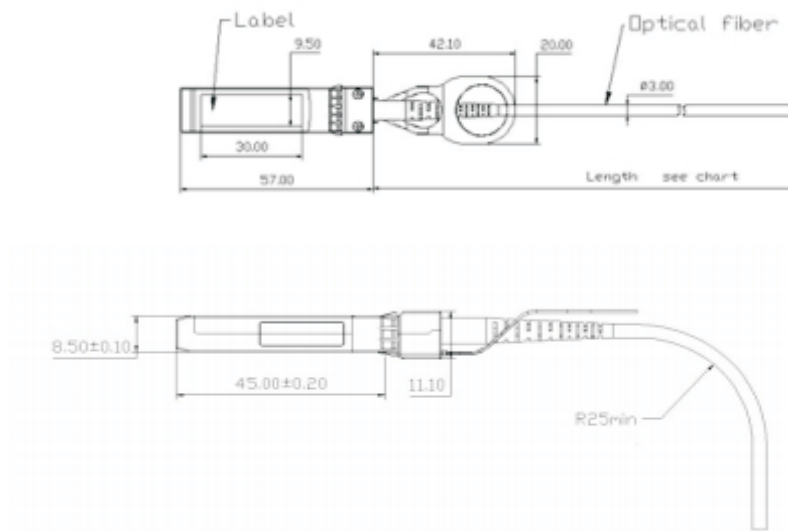

SFP+ AOC end Mechanical Specifications

Ordering Information

Parameter	Total Length	Breakout point (measured from QSFP)	Breakout point (measured from SFP+)
AOC-QSFP+/4SFP+01M	1m	30cm	70cm
AOC-QSFP+/4SFP+02M	2m	60cm	1.4m
AOC-QSFP+/4SFP+03M	3m	1m	2m
AOC-QSFP+/4SFP+05M	5m	2m	3m
AOC-QSFP+/4SFP+07M	7m	4m	3m
AOC-QSFP+/4SFP+10M	10m	7m	3m
AOC-QSFP+/4SFP+15M	15m	12m	3m
AOC-QSFP+/4SFP+20M	20m	17m	3m
AOC-QSFP+/4SFP+25M	25m	22m	3m
AOC-QSFP+/4SFP+30M	30m	27m	3m
AOC-QSFP+/4SFP+40M	40m	37m	3m
AOC-QSFP+/4SFP+50M	50m	47m	3m
AOC-QSFP+/4SFP+xxM	Custom M		3m

*For availability of additional cable lengths, please contact LUXGLO