

# 400Gbs QSFP-DD AOC Cable Specification

## **Features**

- QSFP-DD MSA compliant
- Compliant to IEEE 802.3bs Specification
- Up to 70m transmission on multi-mode fiber (MMF) OM3 with FEC
- Operating case temperature: 0 to 70°C
- 8x53.125Gb/s electrical interface (400GAUI-8)
- Data Rate 53.125Gbps (PAM4) per channel
- Maximum power consumption 11W
- RoHS complaint

## **Applications**

- Data Center Interconnect
- 400G Ethernet
- Enterprise networking

## **1. General Description**

The product is a parallel 400Gb/s Quad Small Form Factor Pluggable--double density (QSFP-DD) optical module. It provides increased port density and total system cost savings. The QSFP-DD full duplex optical module offers 8 independent transmit and receive channels, each capable of 53.125Gb/s operation for an aggregate data rate of 400Gb/s on 70 meters of OM3 multi-mode fiber. Proper alignment is ensured by the guide pins inside the receptacle. The cable usually cannot be twisted for proper channel to channel alignment. Electrical connection is achieved through an QSFP-DD MSA-compliant edge type connector. The central wavelengths of all the 8 parallel lanes are 850nm. Host FEC is required to support up to 70m OM3 multi-mode fiber transmission.

## 2. Function Description

The module incorporates 8 parallel channels, on 850nm Center Wavelength, operating at 50G per channel. The transmitter path incorporates an 8-channel CDR retimer, 2 sets of quad channel VCSEL drivers together with 2 sets of VCSEL arrays. On the receiver path, 2 sets of photodiode arrays optics are coupled with an 8-channel CDR retimer. The electrical interface is compliant with IEEE 802.3bs and QSFP-DD MSA in the transmitting and receiving directions. Figure 2.1 shows the functional block diagram of this product.

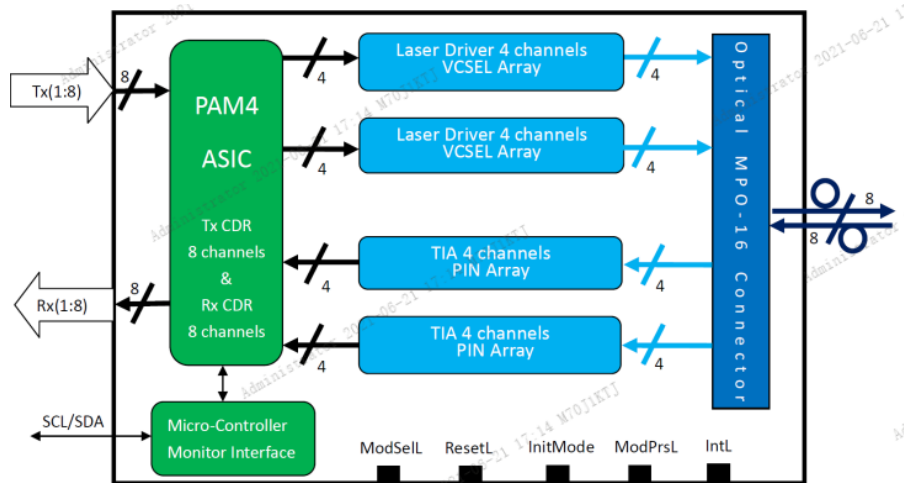

Figure 2.1 Transceiver Block Diagram

### 3. Absolute Maximum Ratings and Recommended Operating Conditions

**Table 3.1 Absolute Maximum Ratings**

Parameter	Min	Max	Unit	Note
Storage Temperature	-40	85	°C	
Storage Relative Humidity (non-condensation)		85	%	
Supply Voltage	-0.5	3.6	V	
Receiver Damage Threshold[1]	5		dBm	

**Table 3.2 Recommended Operating Conditions**

Parameter	Min	TYP.	Max	Unit	Note
Operating Case Temperature	0		70	°C	
Power Supply Voltage	3.13		3.47	V	
Power Supply Current			3.3	A	
Total Power Consumption			11	W	
Data Rate(Electrical)		26.5625		GBd	
Data Rate Accuracy	-100		100	ppm	
Transmission Distance	70m(OM3) or 100m(OM4)			m	1
Pre-FEC Bit Error Ratio			2e-4		
Post-FEC Bit Error Ratio			1e-12		2

Notes:

[1] FEC required on host system to support maximum distance.

[2] FEC provided by host system.

## 4. Electrical Specifications

**Table 4.1 High Speed Electrical Specifications**

Parameters	Min	Typ.	Max	Unit	Note
Input Differential Impedance		100		$\Omega$	
Differential pk-pk Input Voltage Tolerance	900			mV	1
Module Stressed Input Test	See IEEE 802.3bs 120E.3.4.1				2
Signaling Rate, each Lane	26.5625 $\pm$ 100 ppm			GBd	PAM4
Single-ended Voltage Tolerance Range (Min)	-0.4 to 3.3			V	
Differential Termination Mismatch			10	%	
AC Common Mode Output Voltage, RMS			17.5	mV	
Differential Output Return Loss	IEEE 802.3-2015 Equation (83E-2)				
Common to Differential Mode Conversion Return Loss	IEEE 802.3-2015 Equation (83E-3)				
Transition Time, 20% to 80%	9.5			ps	
Near-end Eye Symmetry Mask Width (ESMW)		0.265		UI	
Near-end Eye Height Differential	70			mV	
Far-end Eye Symmetry Mask Width (ESMW)		0.2		UI	
Far-end Eye Height, Differential	30			mV	
Far-end Pre-cursor ISI Ratio	-4.5		2.5	%	
Common Mode Output Voltage (Vcm)	-350		2850	mV	3

Notes:

[1] With the exception to IEEE 802.3bs 120E.3.1.2 that the pattern is PRBS31Q or scrambled idle.

[2] Meets BER specified in IEEE 802.3bs 120E.1.1.

[3] DC common mode voltage generated by the host. Specification includes effects of ground offset voltage.

## 5. Digital Diagnostic Monitor Accuracy

The following characteristics are defined over recommended operating conditions.

Table 5.1 Digital Diagnostic Monitor Accuracy

Parameter	Accuracy	Unit
Internally Measured Transceiver Temperature	±3	deg.C
Internally Measured Transceiver Supply Voltage	±5	%
Measured Tx Bias Current	±10	%
Measured Tx Output Power	±3	dB
Measured Rx Received Average Optical Power	±3	dB

## 6. Pin Assignment and Pin Description

The electrical pinout of the QSFP-DD module is shown as Figure 6.1

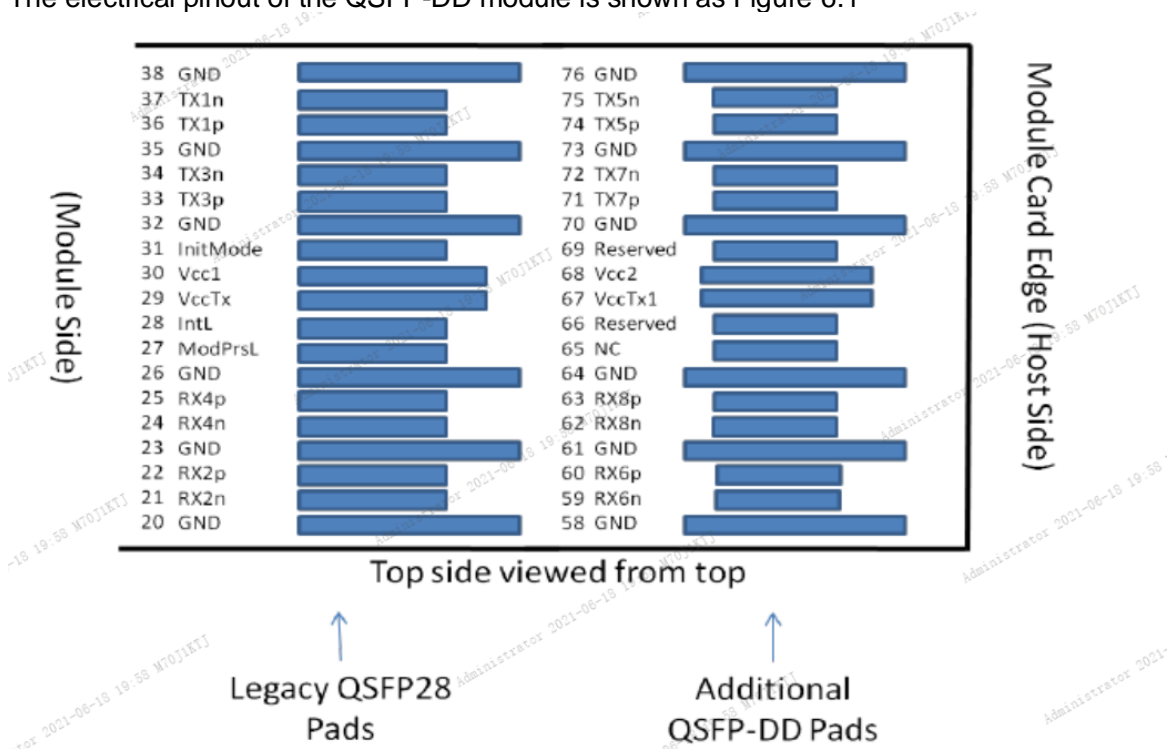

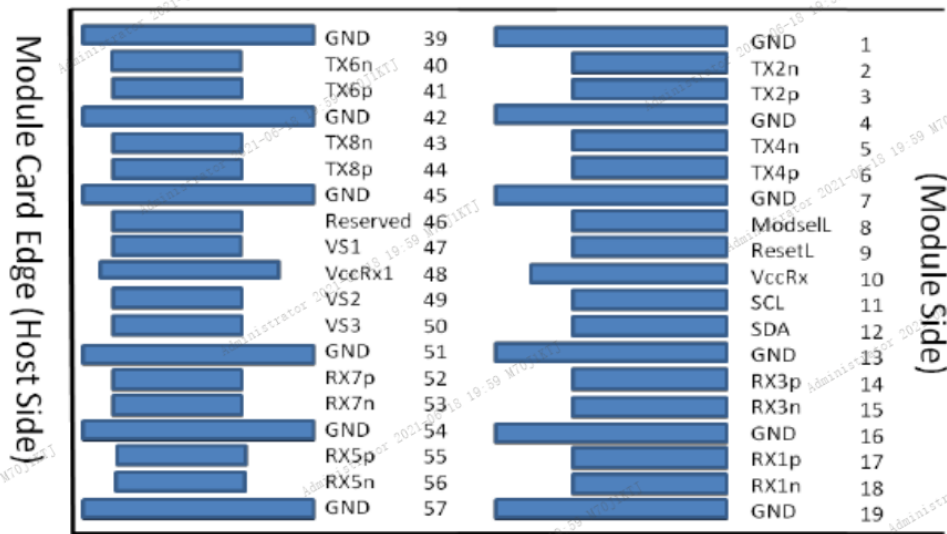

Bottom side viewed from bottom

Additional  
QSFP-DD Pads

Legacy QSFP28  
Pads

Figure 6.1 MSA Compliant Connector

## Pin Description

Pin #	Logic	Symbol	Description	Plug Sequence
1		GND	Ground	1B
2	CML-I	Tx2n	Transmitter Inverted Data Input	3B
3	CML-I	Tx2p	Transmitter Non-Inverted Data Input	3B
4		GND	Ground	1B
5	CML-I	Tx4n	Transmitter Inverted Data Input	3B
6	CML-I	Tx4p	Transmitter Non-Inverted Data Input	3B
7		GND	Ground	1B
8	LVTTTL-I	ModSelL	Module Select	3B
9	LVTTTL-I	ResetL	Module Reset	3B
10		VccRx	+3.3V Power Supply Receiver	2B
11	LVCNOS-I/O	SCL	2-wire serial interface clock	3B
12	LVCNOS-I/O	SDA	2-wire serial interface data	3B
13		GND	Ground	1B
14	CML-O	Rx3p	Receiver Non-Inverted Data Output	3B
15	CML-O	Rx3n	Receiver Inverted Data Output	3B
16		GND	Ground	1B
17	CML-O	Rx1p	Receiver Non-Inverted Data Output	3B
18	CML-O	Rx1n	Receiver Inverted Data Output	3B
19		GND	Ground	1B
20		GND	Ground	1B
21	CML-O	Rx2n	Receiver Inverted Data Output	3B
22	CML-O	Rx2p	Receiver Non-Inverted Data Output	3B
23		GND	Ground	1B
24	CML-O	Rx4n	Receiver Inverted Data Output	3B
25	CML-O	Rx4p	Receiver Non-Inverted Data Output	3B
26		GND	Ground	1B
27	LVTTTL-O	ModPrsL	Module Present	3B
28	LVTTTL-O	IntL	Interrupt	3B
29		VccTx	+3.3V Power supply transmitter	2B
30		Vcc1	+3.3V Power supply	2B
31	LVTTTL-I	InitMode	Initialization mode; In legacy QSFP applications, the InitMode pad is called LPMODE	3B
32		GND	Ground	1B
33	CML-I	Tx3p	Transmitter Non-Inverted Data Input	3B
34	CML-I	Tx3n	Transmitter Inverted Data Input	3B
35		GND	Ground	1B
36	CML-I	Tx1p	Transmitter Non-Inverted Data Input	3B
37	CML-I	Tx1n	Transmitter Inverted Data Input	3B
38		GND	Ground	1B
39		GND	Ground	1A
40	CML-I	Tx6n	Transmitter Inverted Data Input	3A

41	CML-I	Tx6p	Transmitter Non-Inverted Data Input	3A
42		GND	Ground	1A
43	CML-I	Tx8n	Transmitter Inverted Data Input	3A
44	CML-I	Tx8p	Transmitter Non-Inverted Data Input	3A
45		GND	Ground	1A
46		Reserved	For future use	3A
47		VS1	Module Vendor Specific 1	3A
48		VccRx1	3.3V Power Supply	2A
49		VS2	Module Vendor Specific 2	3A
50		VS3	Module Vendor Specific 3	3A
51		GND	Ground	1A
52	CML-O	Rx7p	Receiver Non-Inverted Data Output	3A
53	CML-O	Rx7n	Receiver Inverted Data Output	3A
54		GND	Ground	1A
55	CML-O	Rx5p	Receiver Non-Inverted Data Output	3A
56	CML-O	Rx5n	Receiver Inverted Data Output	3A
57		GND	Ground	1A
58		GND	Ground	1A
59	CML-O	Rx6n	Receiver Inverted Data Output	3A
60	CML-O	Rx6p	Receiver Non-Inverted Data Output	3A
61		GND	Ground	1A
62	CML-O	Rx8n	Receiver Inverted Data Output	3A
63	CML-O	Rx8p	Receiver Non-Inverted Data Output	3A
64		GND	Ground	1A

65		NC	No Connect	3A
66		Reserved	For future use	3A
67		VccTx1	3.3V Power Supply	2A
68		Vcc2	3.3V Power Supply	2A
69		Reserved	For Future Use	3A
70		GND	Ground	1A
71	CML-I	Tx7p	Transmitter Non-Inverted Data Input	3A
72	CML-I	Tx7n	Transmitter Inverted Data Input	3A
73		GND	Ground	1A
74	CML-I	Tx5p	Transmitter Non-Inverted Data Input	3A
75	CML-I	Tx5n	Transmitter Inverted Data Input	3A
76		GND	Ground	1A

Note:

- [1] GND is the symbol for signal and supply (power) common for the QSFP28 module. All are common within the QSFP28 module and all module voltages are referenced to this potential unless otherwise noted. Connect these directly to the host board signal-common ground plane.
- [2] Vcc Rx, Vcc1 and Vcc Tx are the receiver and transmitter power supplies and shall be applied concurrently.
- [3] Not used.



## 7. Package Dimensions

Figure 7.1 shows the package dimensions of the module. The module is designed to be compliant with QSFP28 MSA specification. Package dimensions are specified in SFF-8661.

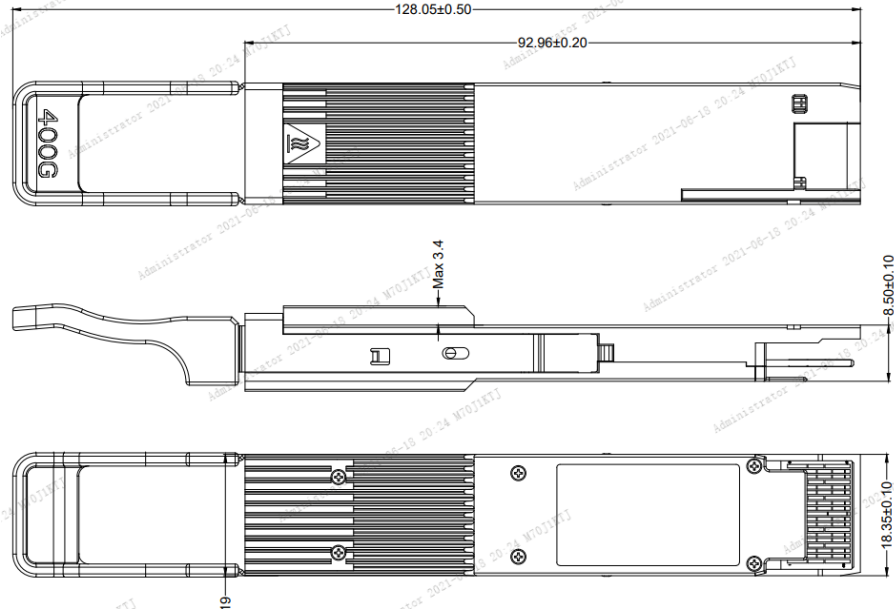

Figure 7.1 Package Dimensions

## 8. Laser safety and Electromagnetic Compatibility

### 8.1 Laser safety

All transceivers are Class 1 Laser products per FDA/CDRH and IEC-60825-1 & IEC60825-2 standards. They must be operated under specified operating conditions.

### 8.2 Electromagnetic Compatibility

All transceivers are designed to meet FCC Class B limits.

## 9. Ordering Information

Part Number	Temperature Range	Distance 70m(OM3) or 100m(OM4)	Fiber Type	E/O	O/E
AOC-D-D-400G-01	0°C to + 70°C	1M	AOC	DML	PIN
AOC-D-D-400G-03	0°C to + 70°C	3M	AOC	DML	PIN
AOC-D-D-400G-10	0°C to + 70°C	10M	AOC	DML	PIN
AOC-D-D-400G-xx	0°C to + 70°C	xxM (Up to 70m)	AOC	DML	PIN